

> MAJORTRIO

WE EXPAND
YOUR PARKING
CAPACITY

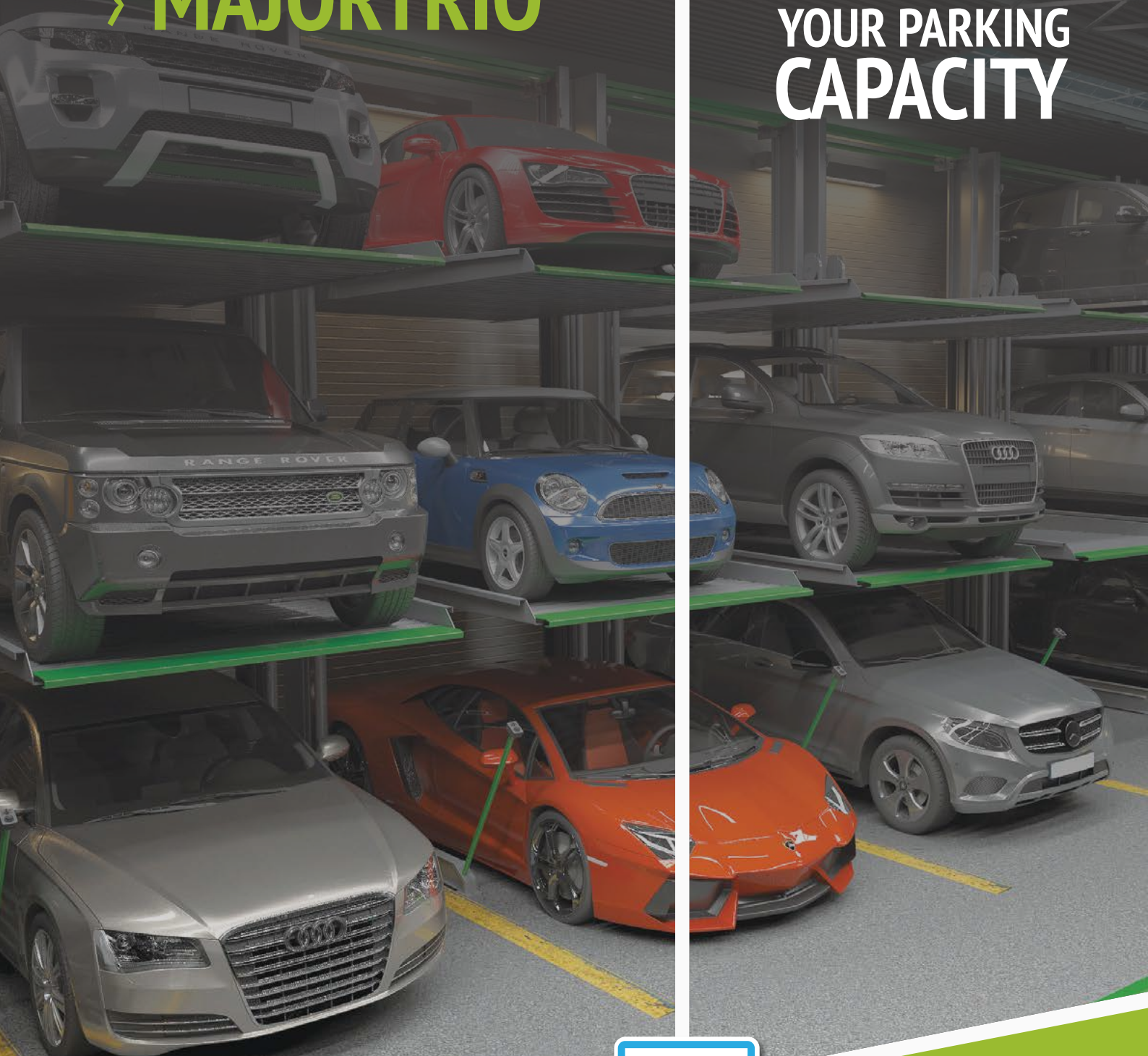

DATASHEET

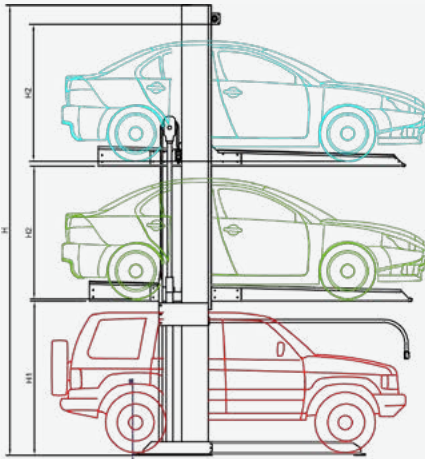

» System lifted

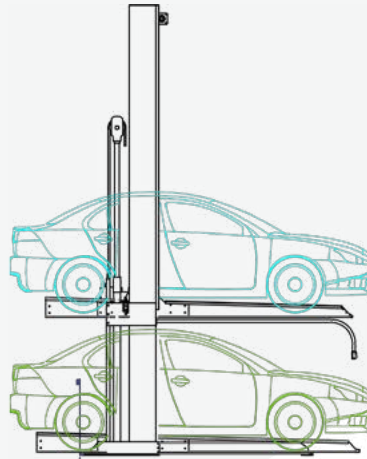

» System in middle position

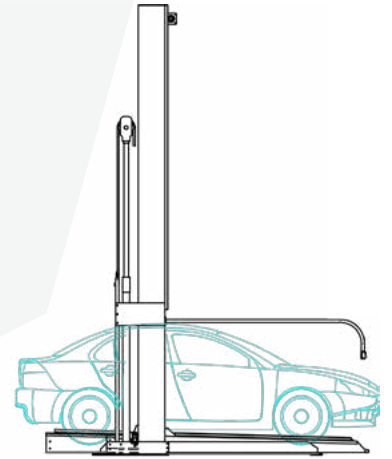

» System lowered

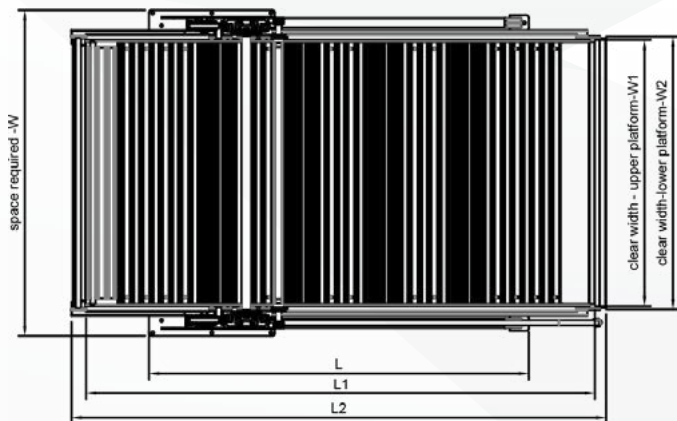

Space required W (cm)	Clear Platform width Upper Level (cm)	Clear Platform width Middle Level (cm)
260	210	220
270	220	230
280	230	240
290	240	250
300	250	260

electrical datas: Hydraulic unit with three-phase motor, 380 V, 50Hz 5,5 KW

Height	Majortrio 515	Majortrio 545	Majortrio 575	Majortrio 605
Height (H)	515 cm	545 cm	575 cm	605 cm
Height (H1)	155 cm	165 cm	175 cm	185 cm
Height (H2)	155 cm	165 cm	175 cm	185 cm
Car Height	150 cm	160 cm	170 cm	180 cm

» CLEARANCE CAR DIMENSIONS

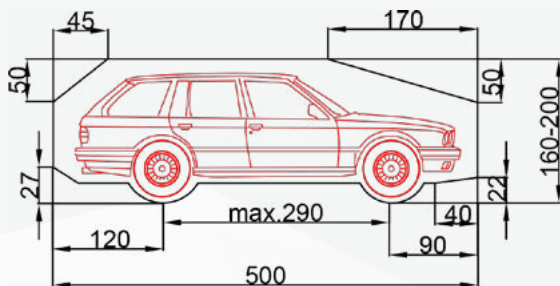

The total car height includes roof rail and antenna. Car height must not exceed the above max. car dimensions.

» STATIC AND CONSTRUCTION REQUIREMENTS INDOOR INSTALLATION

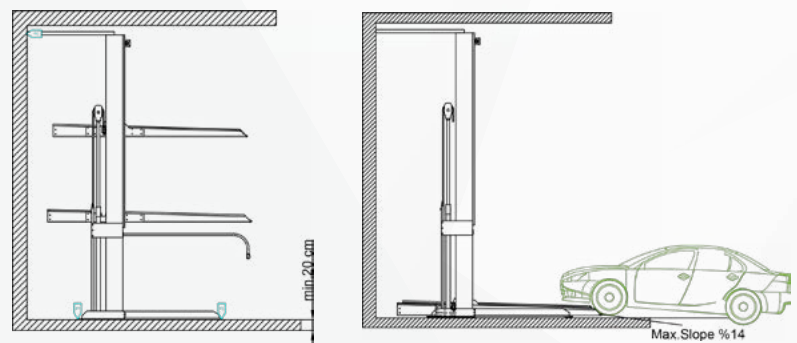

INDOOR LOAD FACTOR	P1	P2	P3
	+22 KN	+20 KN	± 6 KN

notes:
Anchor bolts depth min.12 cm

Base plate thickness minimum 20 cm. Concrete quality min.C25/30

» STATIC AND CONSTRUCTION REQUIREMENTS OUTDOOR INSTALLATION

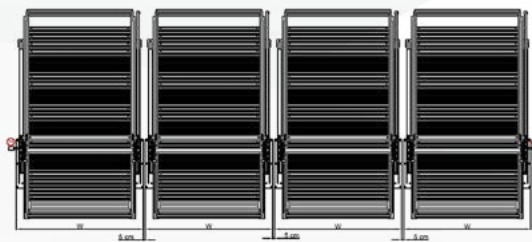
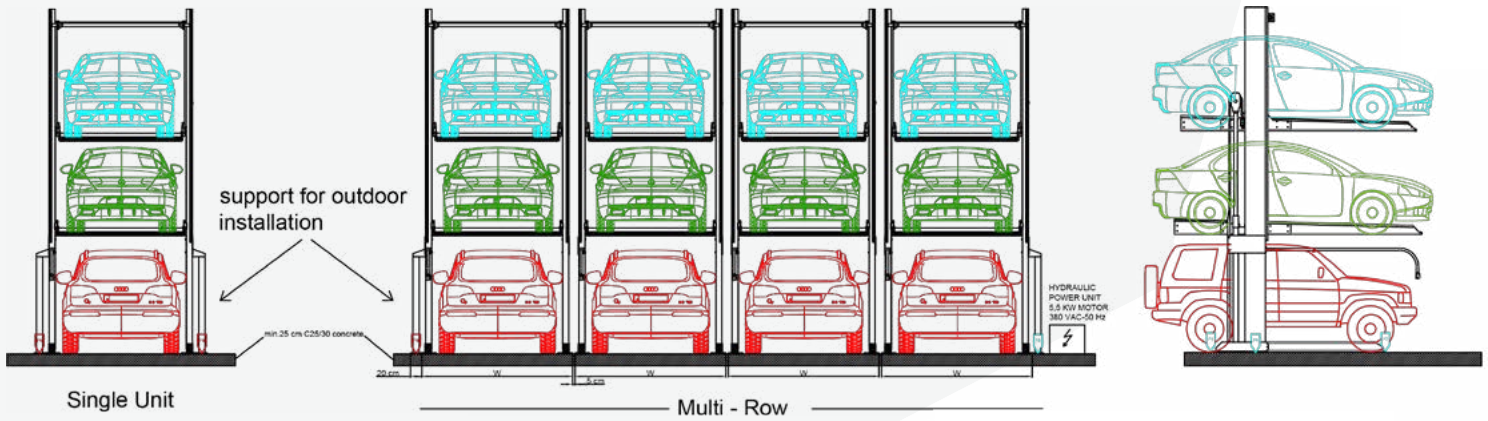

INDOOR LOAD FACTOR	P1	P2	P4
	+28 KN	+24 KN	± 9 KN

notes:
Anchor bolts depth min.12 cm

Base plate thickness minimum 20 cm. Concrete quality min.C25/30

» TECHNICAL SPECIFICATION

- › Mostly use for indoor, without pit, facility to increase parking capacity by 3 times.
- › Adjustable lifting height for each platform and suitable design for one SUV and 2 sedan cars.
- › No need building for concrete and asphalt ground if there is enough thickness concrete.
- › Most suitable and fastest solution for commercial parking areas, hotels, shopping centres, airports and all other heavy parking areas.

» STANDART EQUIPMENT

- › Hot dip galvanized platforms.
- › Hydraulic and mechanic synchronization system.
- › In common use minimum 3, maximum 6 group type electro - hydraulic power pack unit.
- › Locked key - switch with emergency stop in dead's man's control.
- › 2000kg lifting capacity per car.
- › Electro-magnetic mechanic position locker controls with a fully automatic button.
- › Mechanical position lock system against hose burst and oil leakage.

» OPTIONAL EQUIPMENT

- › Hot Dip galvanized for all steel parts.
- › Audible and illuminated warning system.
- › Vehicle detection sensor.
- › Production possibility for special requirements; more lifting capacity or wider platforms etc.
- › Separate hydraulic power pack, electric and control system for each unit.